

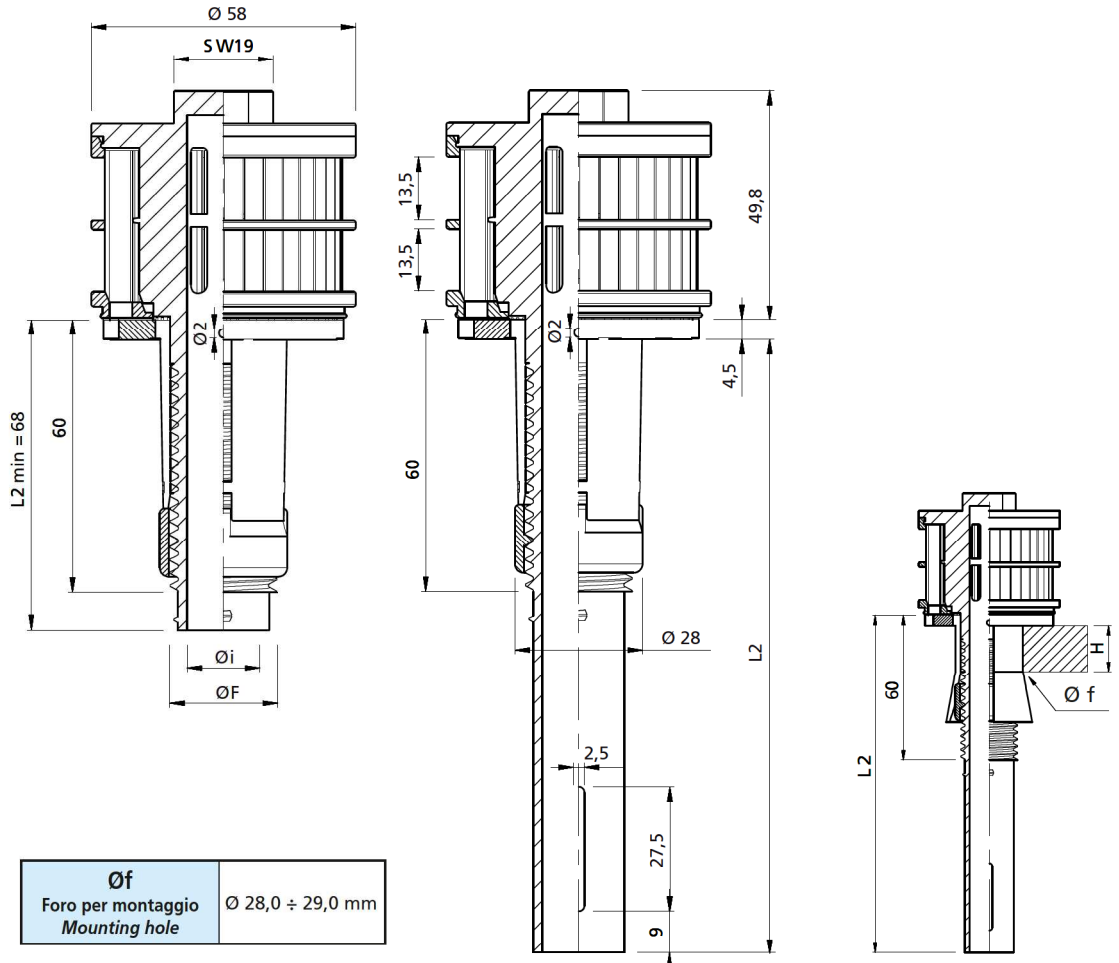

- Universale
- Ampia gamma di fessure
- Ampia superficie filtrante
- Di facile pulizia mediante controlavaggio
- Molto robusto
- Per montaggio dal solo lato ugello
- Fornito preassemblato pronto per installazione

- Multipurpose
- Wide range of slots
- Wide filtering area
- Easily cleaning by backwash
- Very strong
- Installed only from the nozzle's side
- Supplied pre-assembled, ready to be installed



Tipo Type	Fessura Slot width mm	N. Fessure Slots No.	Sezione Area mm ²
R	0,20	40	216
	0,25	40	270
	0,30	36	291
	0,35	36	340
	0,50	36	486
	0,60	36	583
	1,00	36	972
	2,00	18	972
	3,00	12	972
5,00	8	1080	

Filetto Thread	ØF mm	Øi mm	Area codolo Stem area mm ²	L min mm	L2 mm	H mm
15/16"W	23,5	16	200	68	68, 80, 100, 120, 140, 160, +5, 400	5....33

Come ordinare How to order	Ugello Nozzle	Fessura Slot width	ID mm	L2 mm	Materiale Material
Esempio / Example	RTL	0,20	16	120	PP

Materiale/Material: PP - PPFV - PVDF

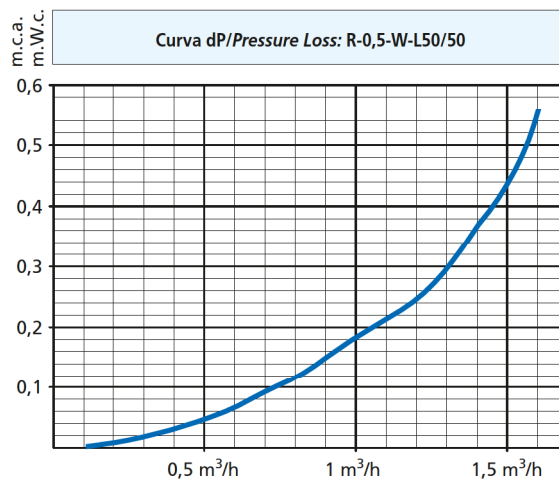
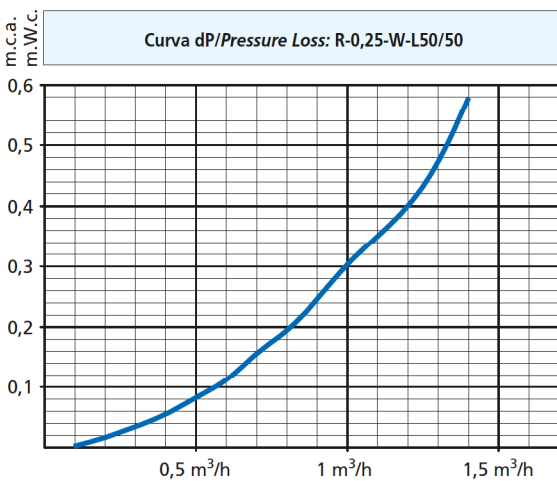

NOTE
Su richiesta, può essere fornita la curva caratteristica di dP di tutti gli ugelli prodotti da ILMAP

On demand, the dP characteristic curve of all the nozzles made by ILMAP can be supplied.